

Suppression of secondary reactions by using “flow-through cup”

[Background] When a small amount of sample is analyzed a low split ratio is often used to increase the amount of sample introduced to the separation column. However, as the flow through the system decreases, the residence time of the pyrolyzates in the sample cup increases. This may result in undesirable secondary reactions. The time needed to flush the pyrolyzates can be reduced by using a “flow-through cup”. The value of using a flow-through cup can be demonstrated using polycarbonate (PC).

[Experimental] An industrially synthesized PC sample using the solvent method was pyrolyzed at 600°C. The flow of helium through the cup was 7 mL/min. Two types of sample cups, flow-through cup LHF shown in Fig.1 and a conventional cup; Eco cup LF, are used in this study.

[Results] The flow diagrams of the carrier gas through the pyrolysis tube around the flow-through and the Eco cup are shown in Fig. 2 (a) and (b), respectively. Obviously, the pyrolyzates are flushed directly through the “flow-through” cup; it takes longer to flush the pyrolyzates from the conventional sample cup. The longer residence time may result in decompositions catalyzed by active points on the cup surface, if present. Fig. 3 shows typical pyrograms of PC using the two different types of cups. With the “flow-through” cup bis-phenol A (BisA) is the prominent main product. There are minor products, phenol (Phe) and p-isopropenyl phenol (IPP) are observed. With the std Eco cup LF, the bisA response is much lower and both phenol and p-isopropenyl phenol are much higher. This difference suggests that the secondary decomposition of Bis-phenol A can be reduced by using a “flow-through” sample cup. When the amount of PC used is increased to a normal amount (30 µg), as shown in Fig. 4 the pyrogram of PC does not show secondary decompositions even using the Eco cup LF.

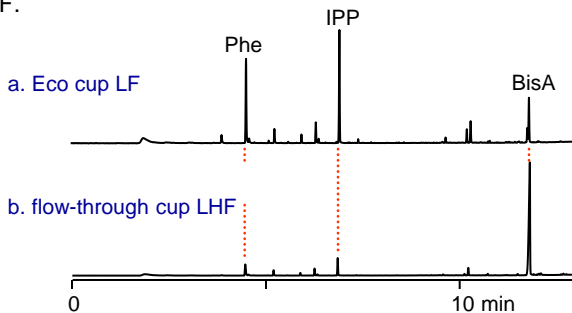
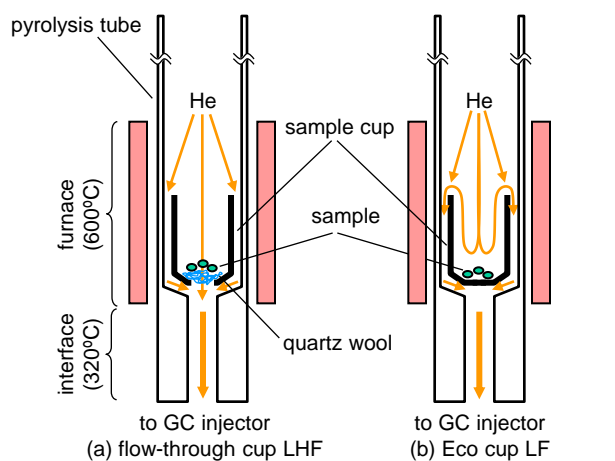
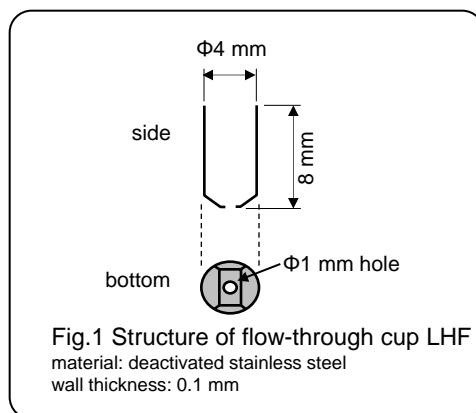

Fig.3 Pyrograms of PC (3 µg) using different sample cups

Pyrolysis temperature: 600°C, GC oven temperature: 40 – 300°C (20 °C/min)
Separation column: Ultra ALLOY⁺-5 (5 % diphenyl 95 % dimethylpolysiloxane, L = 30 m, i.d. = 0.25 mm, df = 0.25 µm), Column gas flow rate: 1.2 mL/min, Split ratio: 1/5, Sample wt: ca 3 µg

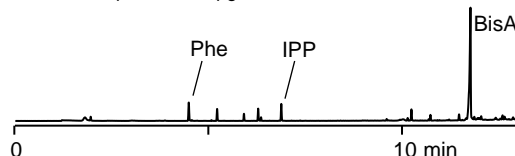

Fig. 4. Pyrogram of PC (30 µg) using Eco cup LF

Split ratio: 1/50, sample: ca. 30 µg, other conditions identical to Fig. 3.

A. Hosaka et al. , *J. Anal. Appl. Pyrolysis* 78 (2007) 452-455

Keywords : Secondary reaction, flow-through cup, polycarbonate

Products used : Multi-functional pyrolyzer, Vent-free GC/MS adapter, UA-5, Flow-through Eco-cup LHF

Applications : General polymer analysis

Related technical notes :

Please forward your inquiries via our web page or send us a fax message.

R&D and manufactured by :
Frontier Laboratories Ltd.

Phone: (81)24-935-5100 Fax: (81)24-935-5102
http://www.frontier-lab.com/